

Workshop

Plan • Outdoor kitchen

FURNITURE WITH SHELF AND DRAWER ON WHEELS WITH SHELVES

Dimensions: (Height) 39" x (Length) 39" x (Depth) 26 1/4"

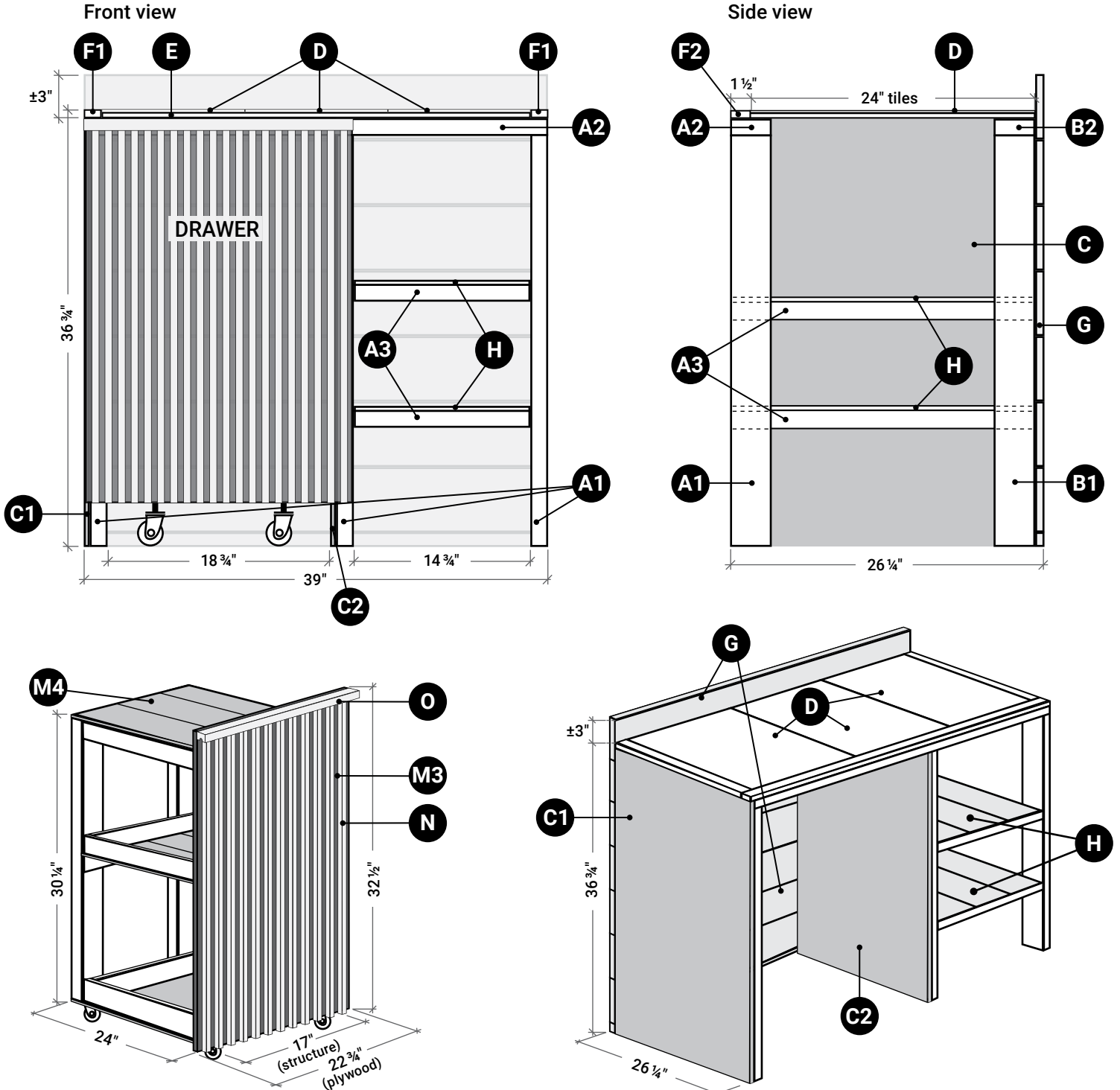

Workshop

Plan • Outdoor kitchen

FURNITURE WITH SHELF

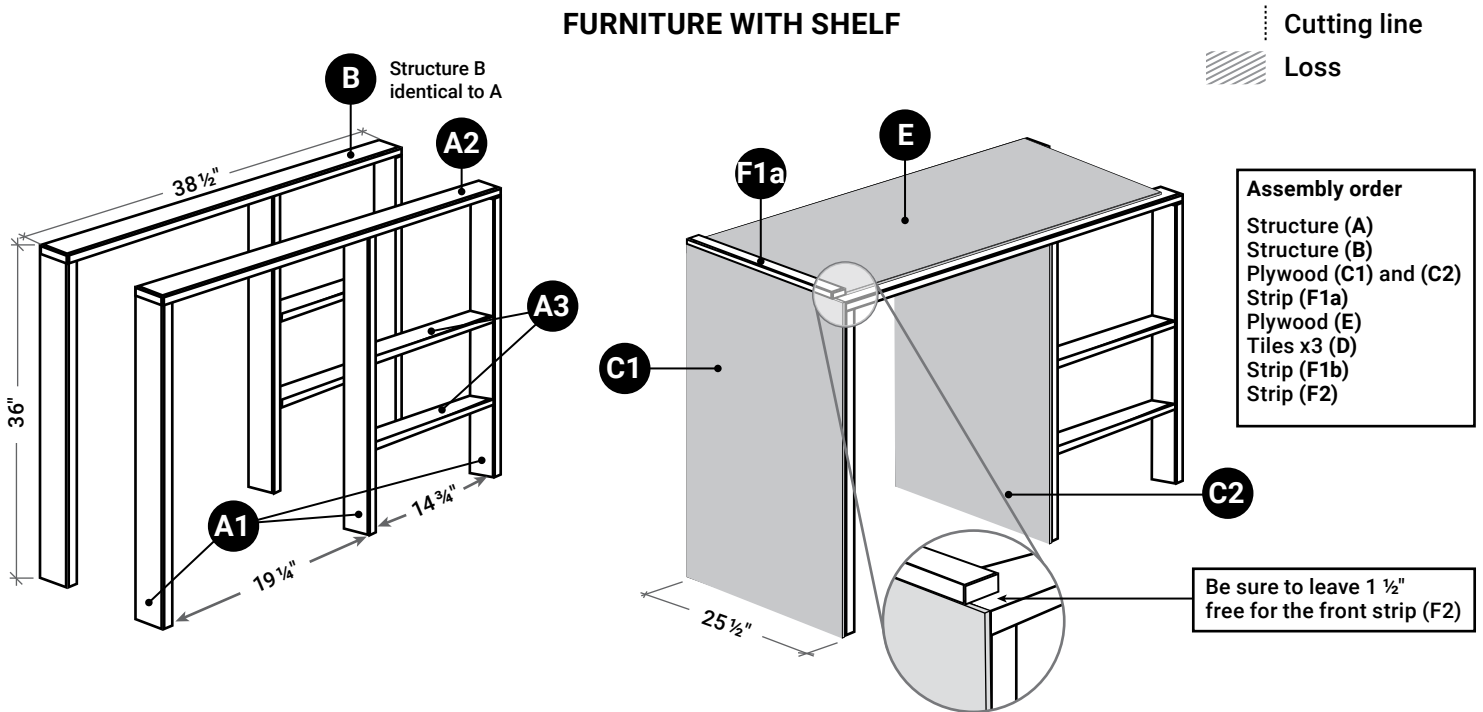

A1 3x (2" x 4" x 34 1/2")

B1 3x (2" x 4" x 34 1/2")

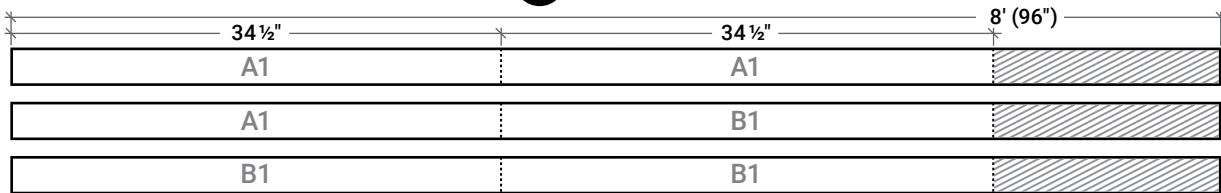

A2 1x (2" x 4" x 38 1/2")

B2 1x (2" x 4" x 38 1/2")

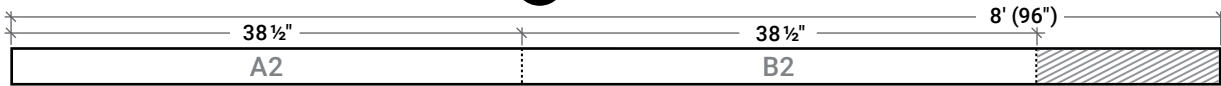

A3 2x (2" x 4" x 14 3/4")

B3 2x (2" x 4" x 14 3/4")



C1 Plywood 1x (1/2" x 25 1/2" x 36")

C2 Plywood 1x (1/2" x 25 1/2" x 34 1/2")

E Plywood 1x (1/2" x 24" x 36")

F1a 1x (1" x 2" x 24")

F1b 1x (1" x 2" x 24")

F2 1x (1" x 2" x 39")

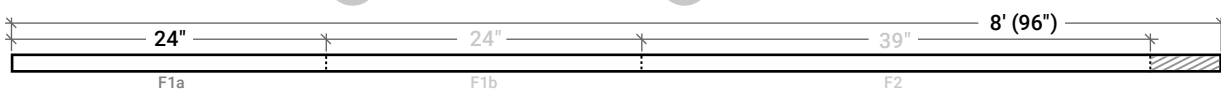

Workshop

Plan • Outdoor kitchen

FURNITURE WITH SHELF

--- Cutting line
 ▨ Loss

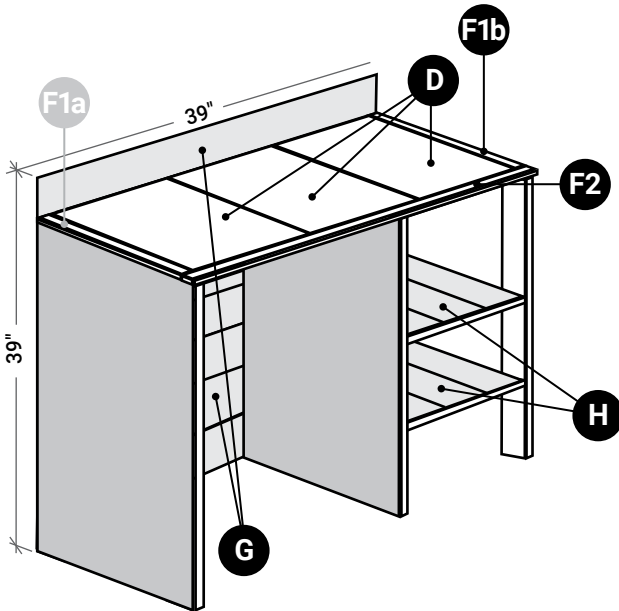

Assembly order	Note / Fence
Tiles (D)	Start with a full board at the top to ensure a good nailing base on the crossbeam of structure B. Allow the board to protrude upwards by about 3". You will need to cut the last bottom board by about 2 3/4".
Strip (F1b)	
Strip (F2)	
Shelf (H)	
Fence (G)	

D Tiles 3x (1/4" x 12" x 24")

F1a 1x (1" x 2" x 24")

F1b 1x (1" x 2" x 24")

F2 1x (1" x 2" x 39")



G 8x (1" x 6" x 39")

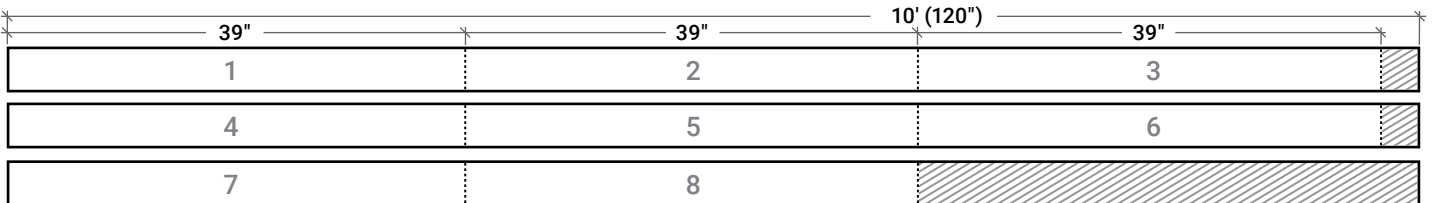

H 4x (1" x 6" x 25 1/2")

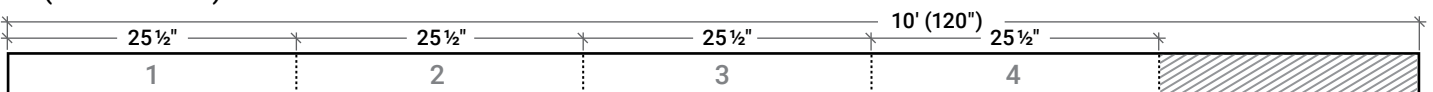

Workshop

Plan • Outdoor kitchen

DRAWER ON WHEELS WITH SHELVES

--- Cutting line
 ▨ Loss

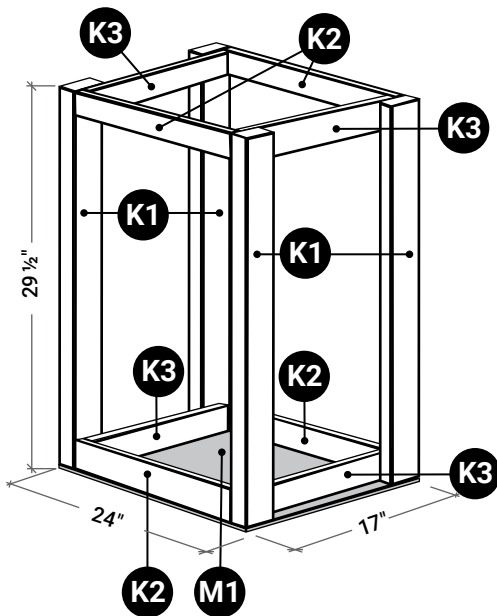

View from the bottom

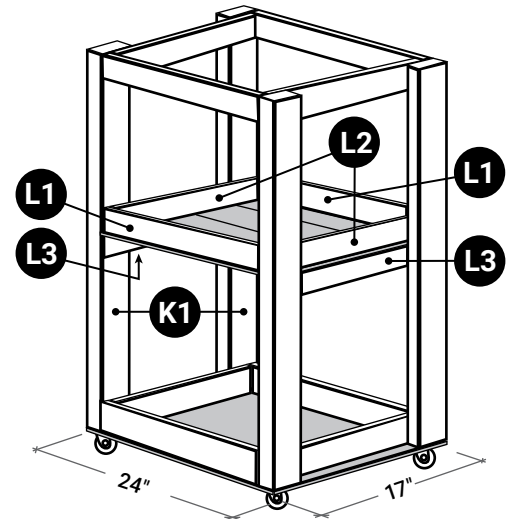
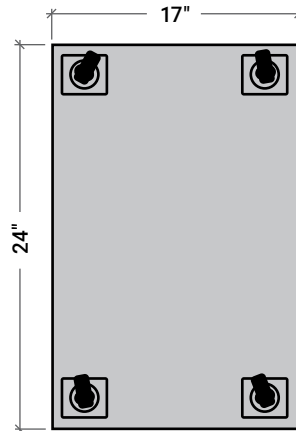

Keep a 1/2" gap between the plywood and the base of the wheel

K1 4x (2" x 4" x 29")

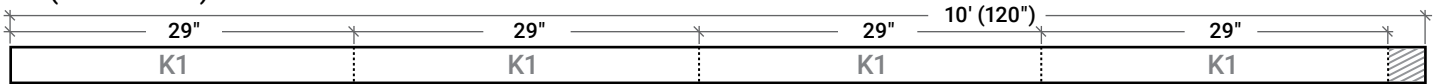

K2 4x (2" x 4" x 21")

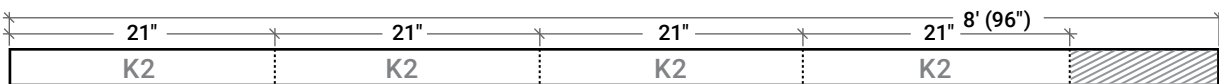

K3 4x (2" x 4" x 14")

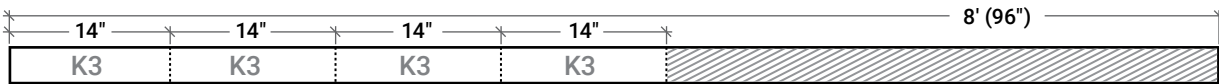

L1 2x (1" x 4" x 21")

L2 2x (1" x 4" x 15 3/4")

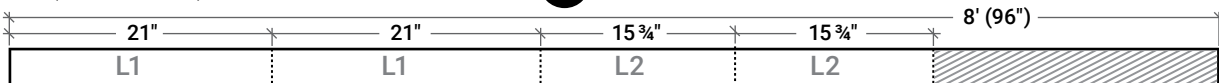

L3 2x (1" x 2" x 17")



Workshop

Plan • Outdoor kitchen

DRAWER ON WHEELS WITH SHELVES

--- Cutting line
 // Loss

Front view
 Position of the plywood
 on the structure

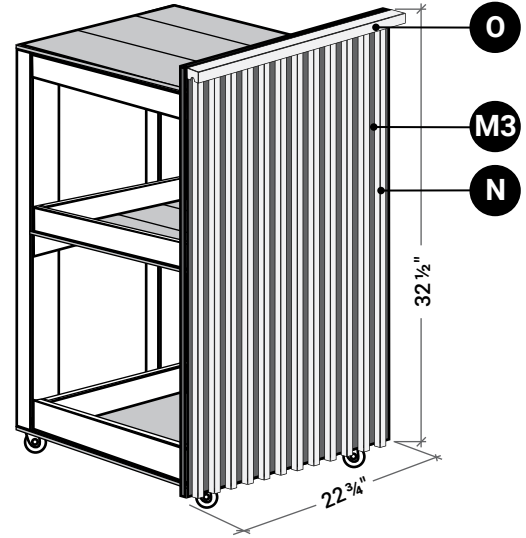
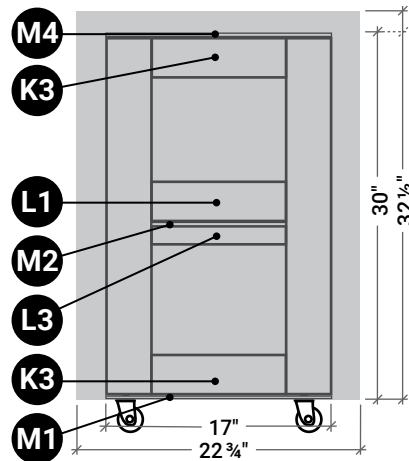
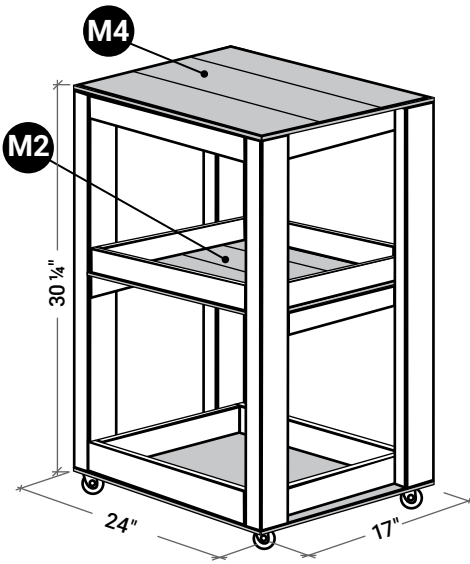

M2 Fence 3x (1" x 6" x 21")

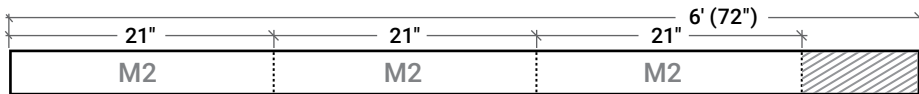

M4 Fence 3x (1" x 6" x 24")

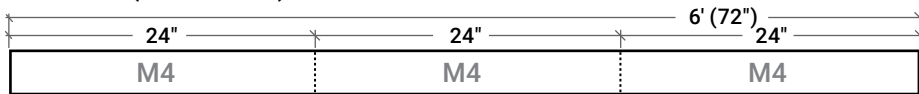

M1 Plywood 1x (1/2" x 17" x 24")

M3 Plywood 1x (1/2" x 22 3/4" x 32 1/2")

N Finishing strips ±13x (1" x 1" x 31 3/4")

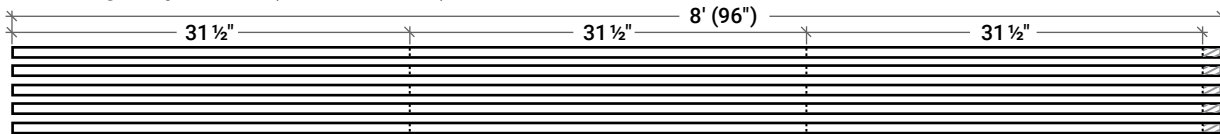

O Moulding in U 1x (1" x 2" x 22 3/4")



Assembly order

- Studs (K1)
- Crossbeams (K2)
- Plywood (M1)
- Wheels
- Strip (L3)
- Boards (M2)
- Strip (L1 - L2)
- Boards (M4)
- Plywood (M3)
- Moulding U (O)
- Strip (N)

Workshop

Plan • Outdoor kitchen

SIMPLE FURNITURE AND DRAWER WITH WHEELS
 Dimensions : (Height) 39" x (Length) 27 3/4" x (Depth) 26 1/4"

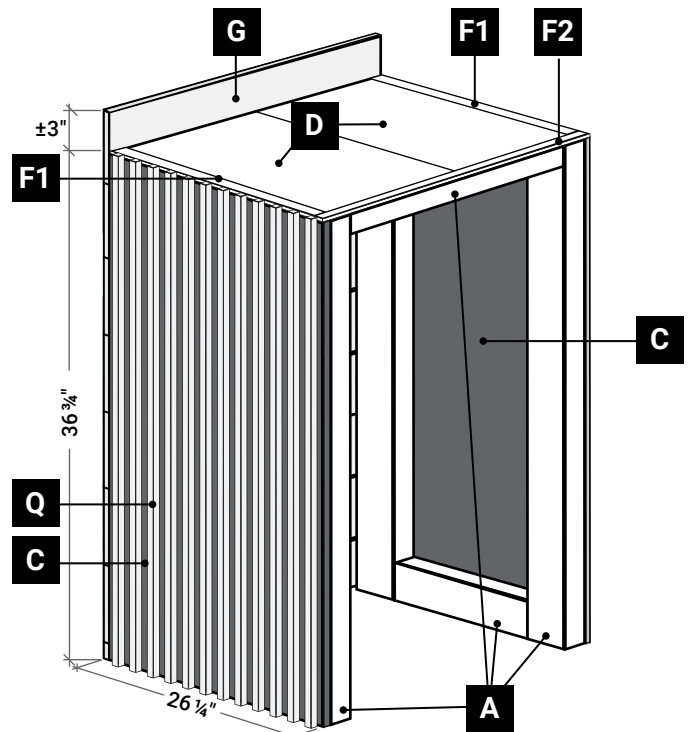
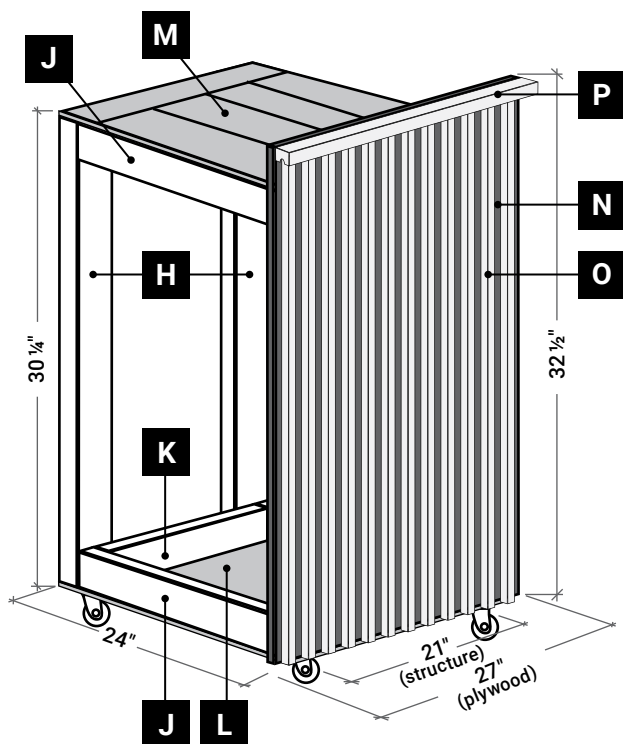
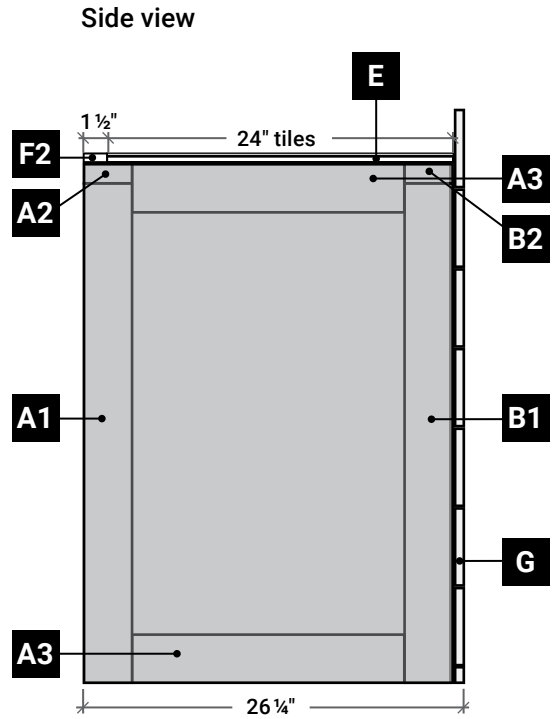
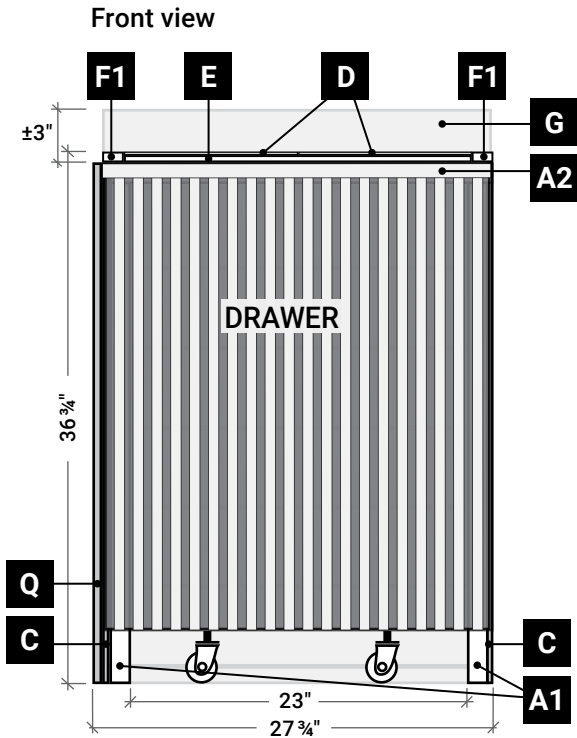

Workshop

Plan • Outdoor kitchen

SIMPLE FURNITURE

--- Cutting line
 // Loss

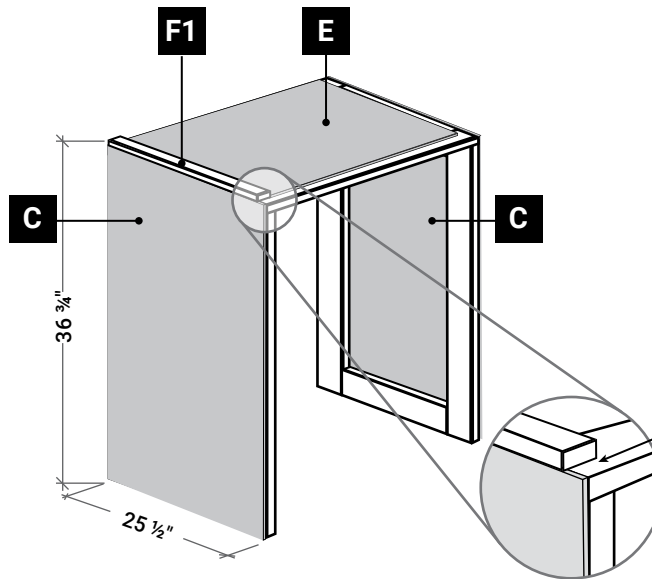
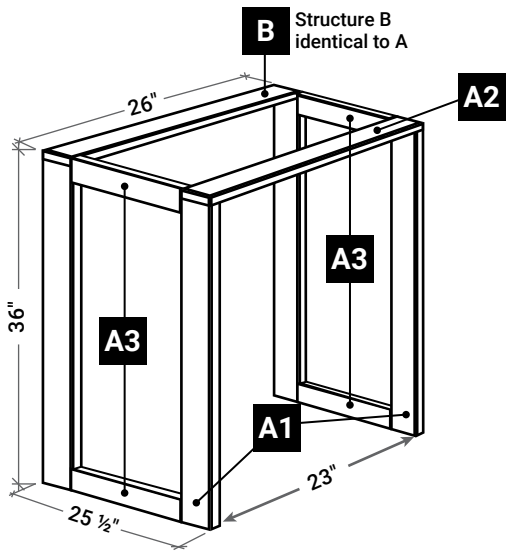

Assembly order
 Structure (A)
 Structure (B)
 Plywood (C1) and (C2)
 Strip (F1a)
 Plywood (E)
 Tiles x3 (D)
 Strip (F1b)
 Strip (F2)

Be sure to leave 1 1/2" free for the front strip (F2)

A1 2x (2" x 4" x 34 1/2")

B1 2x (2" x 4" x 34 1/2")

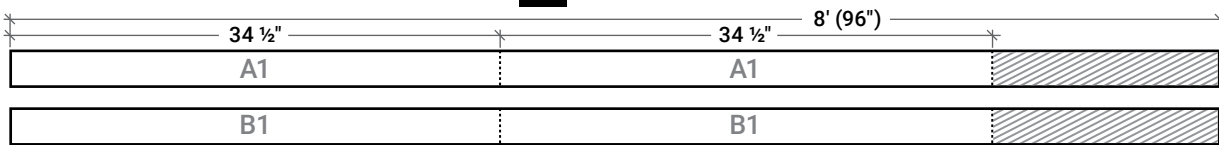

A2 1x (2" x 4" x 26")

B2 1x (2" x 4" x 26")

A3 4x (2" x 4" x 18 1/2")

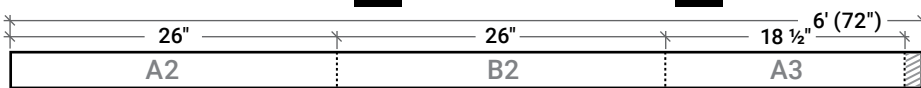

A3 4x (2" x 4" x 18 1/2")



C Plywood 2x (1/2" x 25 1/2" x 36")

E Plywood 1x (1/2" x 24" x 24")

F1 1x (1" x 2" x 24")

F2 1x (1" x 2" x 26")

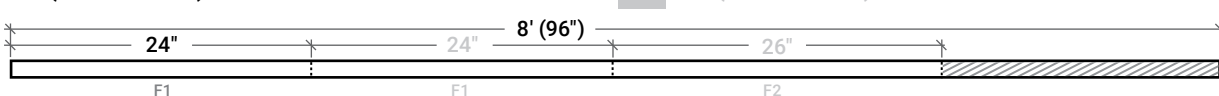

Workshop

Plan • Outdoor kitchen

SIMPLE FURNITURE

--- Cutting line
 ▨ Loss

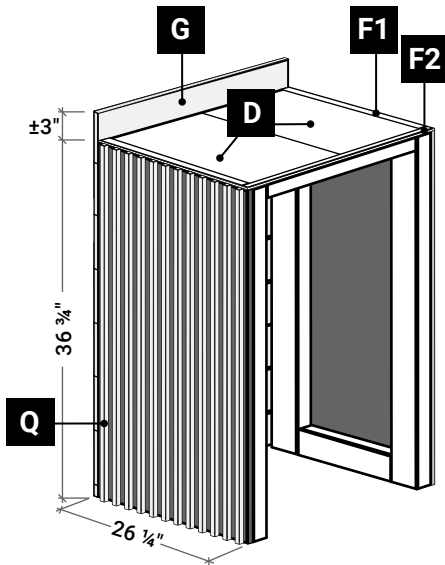

D Tiles 2x (1/4" x 12" x 24")

F1 1x (1" x 2" x 24")

F2 1x (1" x 2" x 26")

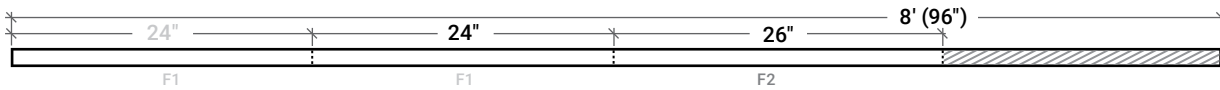

G 8x (1" x 6" x 26")

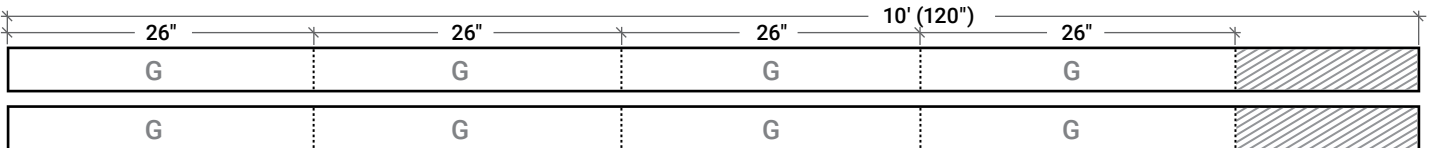

Q Finishing strips ±17x (1" x 1" x 36")

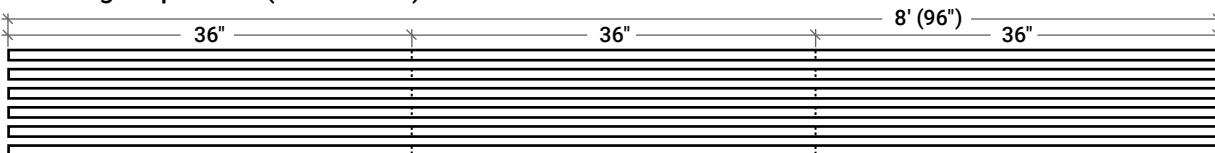

Workshop

Plan • Outdoor kitchen

DRAWER WITH WHEELS

--- Cutting line
 ▨ Loss

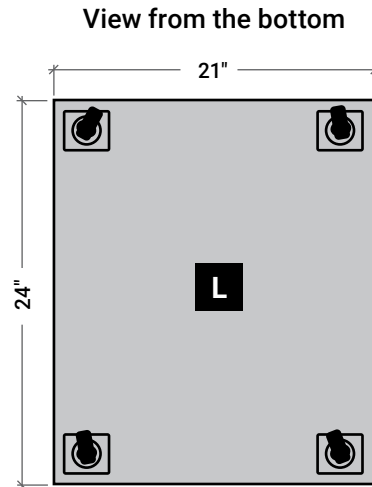
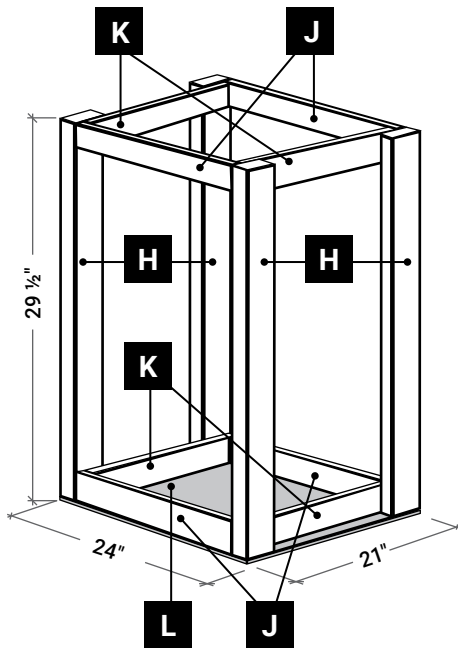

Keep a 1/2" gap between the edge of the plywood and the base of the wheel

H 4x (2" x 4" x 29")

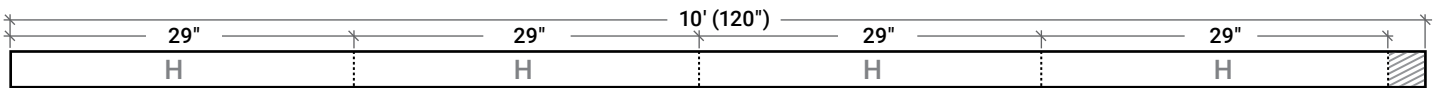

J 4x (2" x 4" x 21")

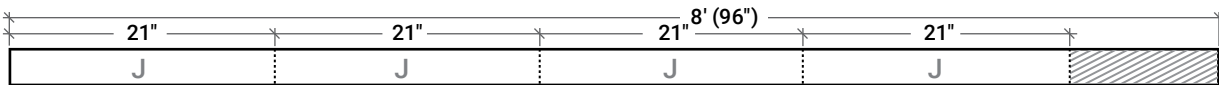

K 4x (2" x 4" x 18")

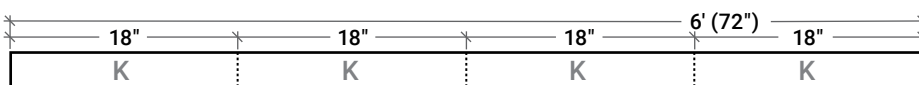

L Plywood 1x (1/2" x 21" x 24")

Assembly order
 Studs (H)
 Crossbeams (J)
 Crossbeams (K)
 Plywood (L)
 Wheels
 Fence (M)
 Plywood (N)
 Moulding U (P)
 Strips (O)

Workshop

Plan • Outdoor kitchen

DRAWER WITH WHEELS

--- Cutting line
 ▨ Loss

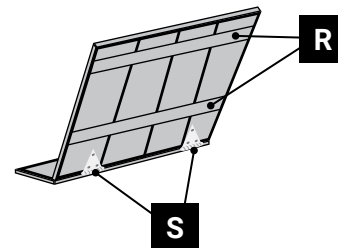
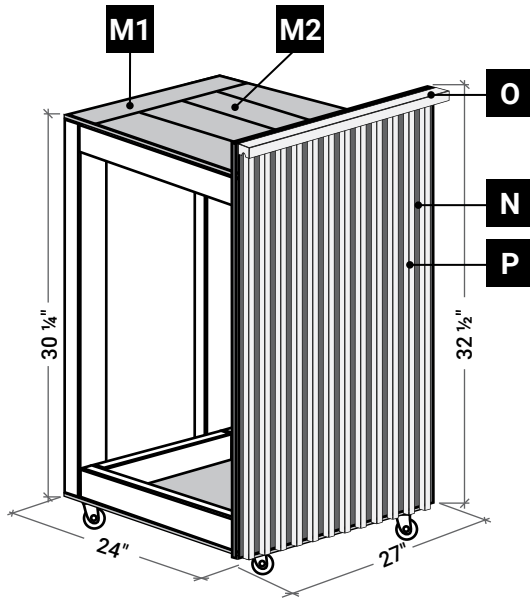

M1 1x (1" x 6" x 21") **M2** 4x (1" x 6" x 18 1/4")

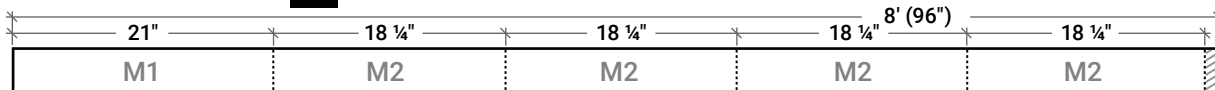

R 2x (1" x 2" x 21")



N Plywood 1x (1/2" x 27" x 32 1/2")

O Moulding in U 1x (1" x 2" x 27")



P Finishing strips ±15x (1" x 1" x 31 3/4")

